

## Matrix

Item	See Model	Book
Service Notes (See Notes).....	Grundig G1000 Chassis	4
X-Ray Precautions (See Notes).....	Grundig G1000 Chassis	4
Circuit Diagram Symbols .....	Grundig CUC 1982	5
Fault Finding Diagram .....	Grundig CUC 7861	5
Colour Decoder Sync PCB Diagram .....	Grundig CUC 7861	5
Control Unit PCB (with Videotext) .....	Grundig CUC 7861	5
CRT PCB Diagram .....	Grundig CUC 7861	5
General Circuit Diagram .....	Grundig CUC 7861	5
IF Amp Diagram (alternative) .....	Grundig CUC 7861	5
Remote Control Diagram .....	Grundig CUC 6360	5
Socket PCB Diagram .....	Grundig CUC 7861	5
Tuner Diagram .....	Grundig CUC 5301	3
Velocity Modulation PCB .....	Grundig CUC 7861	5

## Recommended Safety Parts

Item	Part No.	Description
<b>E72 911</b>		
WW.	09246-188.31	Degaussing Coil
	09246-188.71	Degaussing Coil
	8300-68-696	Pict. Tube A 68 KZN 696X01
	29703-291.81	Power Switch
	29201-361.17	Focus and UG2 Control
R 816, R817	8766-701-027	KSW SI A 12 OHM 5% -GA
WW. = Optional		
<b>M72 795</b>		
	8300-68-696	Pict. Tube A68 KZN 696X01
	29201-360.11	CRT Socket
	09621-113.02	Fuse Holder
	29303-452.02	Mains Plug, Lower Part
	29703-291.32	Power Switch
	8290-991-307	Power Cable
	29201-361.17	Focus and UG 2 Control
C 6001	8511-793-047	MP 3 0,47 UF 20% 250VW
C 6002	8511-793-033	MP 3 0,22 UF 20% 250VW
L 6001	29500-809.97	FUNKENTSTOERDR
R1876, R1877	8766-701-027	KSW SI A 12 OHM 5% -GA
R 6009	8311-200-010	DUO-PTC
SI 6001	8315-622-503	FS.3,15 A/T L 250V
TR6010	09032-301.02	NETZTRAFO
<b>M72 795/9</b>		
WW.	09246-188.31	Degaussing Coil
	09246-188.71	Degaussing Coil
	8300-68-696	Pict. Tube A 68 KZN 696X01
	09621-113.02	Fuse Holder
	29303-452.02	Mains Plug, Lower Part
	29703-291.32	Power Switch
C 6001	8511-793-047	MP 3 0,47 UF 20% 250VW
C 6002	8511-793-033	MP 3 0,22 UF 20% 250VW
L 6001	29500-809.97	FUNKENTSTOERDR
R1876, R1877	8766-701-027	KSW SI A 12 OHM 5% -GA
R 6009	8311-200-010	DUO-PTC
SI 6001	8315-622-503	FS.3,15 A/T L 250V
TR6010	09032-301.02	NETZTRAFO
WW. = Optional		
<b>CUC 7851 (M72 795)</b>		
C 7	29201-361.17	Focus and UG 2-Control
C 621, C 622	8531-505-221	MKT 680PF 20% 12,5KV
C 665	8600-098-238	SI-KERKO B-SS 2200PF 20%
C 666	8660-098-234	SI-KERKO B-SS 1000PF 20%
OK 637,	8515-912-063	FKP1 0,033UF 20% 630V
OK 646	8306-000-012	OPTOKOPPLER CNY 17 F1
R 503	8701-230-817	NKS 3 4,7 OHM 5% >>>RES
R 520	8705-329-071	MOW LI 0411 820 OHM 5%
R 525	8735-003-068	DW 0,75W 0,68 OHM 10%
R 552	8700-329-009	KSW LI 0207-NE 2,2 OHM
R 665	8766-349-155	MSW LI 0414 2,7 MOHM
R 667	8735-002-013	DRW 2 W 0,1 OHM 10%
R 6009	8311-200-010	DUO-PTC
SI 401, SI 406,		
SI 411	8135-616-205	LOET-SI.-GR 800 MA/T
SI 630	8315-619-028	LOET-SI.-GR 1,6 A/T
SI 671	8315-622-025	LOET-SI.-GR 3,15 A/T
SI 691	8315-623-008	LOET-SI.-GR 4 A/T
SI6001	8315-622-003	FS.3,15 A/T L 250V
TR 8	29201-445.97	FOKUSIERUEBERTRAGER
TR 410	29201-382.97	UEBERTRAGER EF20
TR 526	29201-030.08	DIODENSPLITTRAFO KPL
TR6010	09302-301.02	NETZTRAFO
TR 651	29201-401.97	SPERRWANDLERTRAFO KPL
WW.	29201-453.01	SPERRWANDLERTRAFO KPL
WW. = Optional		

## Recommended Safety Parts Cont'd.

Item	Part No.	Description
R 525	8735-003-068	DW 0,75W 0,68 OHM 10%
R 552	8700-329-009	KSW AX 0207-GA NB
R 665	8766-349-155	MSW LI 0414 2,7 MOHM
R 667	8735-002-013	DRW 2 W 0,1 OHM 10%
SI 401, SI 406,		
SI 411	8135-616-205	LOET-SI.-GR 800 MA/T
SI 630	8315-619-028	LOET-SI.-GR 1,6 A/T
SI 671	8315-622-025	LOET-SI.-GR 3,15 A/T
SI 691	8315-623-008	LOET-SI.-GR 4 A/T
TR 8	29201-445.97	FOKUSIERUEBERTRAGER
TR 410	29201-382.97	UEBERTRAGER
TR 526	29201-030.08	DIODENSPLITTRAFO KPL
TR 651	29201-401.97	SPERRWANDLERTRAFO KPL
WW.	29201-453.01	SPERRWANDLERTRAFO KPL
WW. = Optional		
<b>CUC 7851 (M72 795/9)</b>		
C 7	29201-361.17	Focus and UG 2-Control
C 621, C 622	8531-505-221	MKT 680PF 20% 12,5KV
C 665	8600-098-238	SI-KERKO B-SS 2200PF 20%
C 666	8660-098-234	SI-KERKO B-SS 1000PF 20%
C 666	8515-912-063	FKP1 0,033UF 20% 630V
OK 637,		
OK 646	8306-000-012	OPTOKOPPLER CNY 17 F1
R 503	8701-230-817	NKS 3 4,7 OHM 5% >>>RES
R 520	8705-329-071	MOW LI 0411 820 OHM 5%
R 525	8735-003-068	DW 0,75W 0,68 OHM 10%
R 552	8700-329-009	KSW AX 0207-GA NB
R 665	8766-349-155	MSW LI 0414 2,7 MOHM
R 667	8735-002-013	DRW 2 W 0,1 OHM 10%
SI 401, SI 406,		
SI 411	8135-616-205	LOET-SI.-GR 800 MA/T
SI 630	8315-619-028	LOET-SI.-GR 1,6 A/T
SI 671	8315-622-025	LOET-SI.-GR 3,15 A/T
SI 691	8315-623-008	LOET-SI.-GR 4 A/T
TR 8	29201-445.97	FOKUSIERUEBERTRAGER
TR 410	29201-382.97	UEBERTRAGER
TR 526	29201-030.08	DIODENSPLITTRAFO KPL
TR 651	29201-401.97	SPERRWANDLERTRAFO KPL
WW.	29201-453.01	SPERRWANDLERTRAFO KPL
WW. = Optional		
<b>CUC 7851 (E72 911)</b>		
C 7	09621-113.02	Fuse Holder
C 621, C 622	8531-505-221	MKT 680PF 20% 12,5KV
C 665	8600-098-238	SI-KERKO B-SS 2200PF 20%
C 666	8660-098-234	SI-KERKO B-SS 1000PF 20%
C 666	8515-912-063	FKP1 0,033UF 20% 630V
C 6001	8511-793-047	MP 3 0,47 UF 20% 250VW
C 6002	8511-793-033	MP 3 0,22 UF 20% 250VW
L 6001	29500-809.97	FUNKENTSTOERDR.
OK 637	8306-000-012	OPTOKOPPLER CNY 17 F1
OK 646	8306-000-012	OPTOKOPPLER CNY 17F1
R 503	8701-230-817	NKS 3 4,7 OHM 5% ROE
R 520	8705-329-071	MOW LI 0411 820 OHM 5%
R 525	8735-003-068	DW 0,75W 0,68 OHM 10%
R 552	8700-329-009	KSW LI 0207-NE 2,2 OHM
R 665	8766-349-155	MSW LI 0414 2,7 MOHM
R 667	8735-002-013	DRW 2 W 0,1 OHM 10%
R 6009	8311-200-010	DUO-PTC
SI 401, SI 406,		
SI 411	8135-616-205	LOET-SI.-GR 800 MA/T
SI 630	8315-619-028	LOET-SI.-GR 1,6 A/T
SI 671	8315-622-025	LOET-SI.-GR 3,15 A/T
SI 691	8315-623-008	LOET-SI.-GR 4 A/T
SI6001	8315-622-003	FS.3,15 A/T L 250V
TR 8	29201-445.97	FOKUSIERUEBERTRAGER
TR 410	29201-382.97	UEBERTRAGER EF20
TR 526	29201-030.08	DIODENSPLITTRAFO KPL
TR6010	09302-301.02	NETZTRAFO
TR 651	29201-401.97	SPERRWANDLERTRAFO KPL
WW.	29201-453.01	SPERRWANDLERTRAFO KPL
WW. = Optional		

## Service and Special Functions

### With the remote control buttons.

### EPROM Version Number

The version number can be called up in the Info Menu with the "AUX" button. The index 02 of the part number (19798-250.02) indicates the EPROM version.

### Changing the Display Brightness

The VFD brightness is changed by pressing the "AUX" --> ◊ + buttons sequentially.

### Programme Lock (protection against unauthorised use)

You can cancel your personal code number via the Info Centre --> Timer --> Security Code by pressing ◂◃ and ◂◃ OK sequentially.

### ATS Reset

Press and hold the "L+" button on the local keyboard while switching on with the mains button. This option activates the ATS function next time the TV is switched on.

### One place/Two Place Programme Selection

Via the Menu Info Centre --> Special Functions --> Settings, Programme Selection can be switched over between 1-9 and 1-99.

### Maximum Programme Number

Via the Menu Info Centre --> Special Functions --> Settings. When storing the channel number "00" at any programme position, programme selection with the ◂◃ buttons is limited to the numbers lower than this position.

### OSD-ON/OSD-OFF All Programmes.

The on screen display can be switched on or off via the Menu Info Centre --> Special Functions --> Settings --> Pict./Sound Options. When selecting the OSD-OFF option the station identifications and scales for the analog values are not displayed.

### OSD-ON/OSD-OFF Individual Programmes

**Note:** only TVs with LED display.

Activate the desired station via the Menu Info Centre --> TV Station Table and enter a decimal point "." at the first place of the station identification. With this setting the display can be switched off for the selected programmes.

### Loading the Average Values

Press and hold the "P" button on the local keyboard and switch the TV on with the mains button. In doing so the analog average values for the programmes 1-99 and AV1- AV5 are loaded in the programme memory IC840, the AV witch-on bit is reset and the ATS bit is set. The individual settings can be entered and stored with the remote control handset.

### ATS Reset

Press and hold the "L+" button the local keyboard and switch the TV on with the mains button.

### Loading the Emergency Data (eg. after changing µP IC850)

Connect pin 1 of the processor to chassis and switch the TV on with the mains button. The EPROM in the processor IC850 is loaded with:

- the data set and the geometry data for the IC TDA 9162
- the white balance data VR, VG and VB for the IC TDA 9162
- the IF and AFC control voltages.

### Hi-Fi Output: off, variable, linear

Via the Audio Menu --> Hi-Fi Output, with the ◂◃ buttons, the AF at the Hi-Fi output can be:

- Switched "off" (display shows P.), normal operation.
- Set to "variable" (display shows PH.), volume level for the Hi-Fi system can be changed via the TV remote control. The loud speakers in the TV receiver are switched off in this case.
- Set to "linear" (display shows PH.), constant level for the Hi-Fi system.

### Switching Over the Sound (multi) Stereo, Mono, FM, NICAM, NICAM B

Via the Audio Menu --> Sound it is possible with the ◂◃ buttons to change over the stereo decoder for the desired sound reception.

### Forced Mono

By entering the option "MONO" or ".ONO" at the 1st, 2nd, 3rd and 4th place of the station name, the stereo decoder can be made to switch over to FM-mono. The "MO" option is not indicated in the display.

### Volume Level Matching

Via the Menu Info Centre --> Settings --> Volume it is possible on RF mode and Peri mode to set a volume offset on each TV programme position (volume level matching).

### Setting the Peri Bit

"AUX" --> "AV".

With the Peri bit set, the control processor evaluates the switching voltage on pin 8 of the EURO-AV-socket AV1 (black) and switches the TV receiver to this input, eg. on descrambler operation.

### Switching over the descrambler:

- Descrambler off
- Descrambler on Auto (Peri bit set)
- Descrambler on Stereo (Peri bit set)
- Descrambler on Mono - L (Peri bit set)
- Descrambler on Mono - R (Peri bit set)

### Copy Function

In operating mode:

Select first the AV signal source eg. AV1, AV2 etc.

- On: "AUX" --> "0/AV" indication "Copy on"
- Off: "AUX" --> "0/AV" indication "Copy off"

### Copying possibilities:

	From	To:
Scart socket, black:	AV1	--> scart socket 2 (orange). --> scart socket 3 (blue).
Scart socket, orange:	AV2	--> scart socket 3 (blue).
Scart socket, blue:	AV3	--> scart socket 2 (orange).
Cinch socket:	AV4	--> scart socket 2 (orange). --> scart socket 3 (orange). --> scart socket 3 (blue).
S-Video socket:	AV5	--> scart socket 2 (orange). --> scart socket 3 (blue).

In stand-by mode:

Select first the AV signal source eg. AV 1, AV 2 etc

- On: "AUX" --> "0/AV". Indication "Copy on".
- Buttons "AUX" --> ◂◃. Indication "COP" in the display. Copying possibilities are the same as before
- To interrupt the copy mode, press button 1 (indication AV.). to continue the copy mode, press "AUX" --> ◂◃.
- To cancel the copy mode press "◂◃" or "power off".

## Service and Special Functions Cont'd

### IR-Data Programmer

With this menu and with the IR-Data Programmer 2 it is possible to store a maximum of 99 programme positions with the data for the TV norm, Peri, 6-place station identification and the fine tuning frequency.

The programmer AP transfers only channels and 4-place station identifications. Call up via the Menu Info Centre --> Special Functions --> IR-Data Programmer.

### Emergency Data

If necessary the emergency data can be read out from the EPROM. See "Service Adjustments".

## Service Adjustments

### Changing the Sharpness

Call up the Info Menu --> Picture Menu --> Sharpness, and change the value with  $\blacktriangleleft$   $\blacktriangleright$ .

### Colour Registration

The colour registration function allows to compensate for differences in the delay between the Y-channel and the chroma channel.

- With the Menu guide call up the "Colour Match" menu via the Service Programme, Info Centre --> Special Functions --> Service --> Code 8500.
- With buttons  $\blacktriangleleft$   $\blacktriangleright$  correct the delay so that the Y chroma signals coincide.

### White Balance

- Call up the White Balance menu via the Info Centre --> Special Functions --> Service --> code 8500.
- With the  $\blacktriangleleft$   $\blacktriangleright$  buttons set the VG (amplification green) and VB (amplification blue) values so that the white rectangular area in the middle of the picture becomes achromatic. Store with OK.

### Tuner AGC

The automatic Gain Control offers two possibilities of adjusting the delayed automatic gain control voltage for the tuner:

- 1: Feed a standard test pattern at a channel in the upper range of the UHF band into the aerial socket. The RF should be 1.5mV (64dBmV). Call up the "Tuner-AGC" menu via the Service Programme Info Centre --> Special Functions --> Service --> Code 8500, select "automatic" and confirm. The control processor will set the correct value for the delayed gain control voltage.
- 2: Feed in a standard test pattern at a UHF channel as high as possible to the aerial socket. Call up the "Tuner-AGC" menu, Info Centre --> Special Functions --> Service --> Code 8500, select "manual" and confirm. With the  $\blacktriangleleft$   $\blacktriangleright$  buttons tune the TV station so that noise just begins to appear in the picture. Then tune in the reverse direction until the picture just becomes noise free. Store with OK.

### AFC-Reference

The AFC control voltage influences the setting of the station (fine tuning) on HF-reproduction and on station search mode.

The Automatic Frequency Control is activated only if the desired programme position is marked with the station identification AV.

- Tune the tuner precisely at a programme position.
- Call up the AFC Reference Menu via Service Programme --> Info Centre --> Special Functions --> Service --> Code 8500 --> with the menu guide and activate with OK.

On activation of the AFC function a voltage level is read out from the IF-amplifier which is used as a reference for AV-programmes and on station search.

### Adjustment of the Screen Grid Voltage $U_{SG}$

- Feed in a test pattern
- With the remote control adjust the screen brightness so that the grey areas just become dark.
- Switch the receiver to AV operation.
- Connect a high-ohmic voltmeter (series resistance 220kOhm approx.) to the test points R, G, B and determine the highest voltage.
- With the control  $U_{SG}$  on the picture tube panel set the highest voltage level to approx. 10V.

### Adjustment of the Bridge Coil L511

- Call up the Geometry Menu via Info Centre --> Special Functions --> Service --> Code 8500. Set the horizontal amplitude to minimum.
- Connect one test probe of a dual-beam oscilloscope to the collector of the transistor T572.
- Connect the second test probe between the diodes D502 and D503.
- Adjust the coil L511 so that the pulse width of both oscillogrammes is the same.

### Adjustment of the Line Sharpness

With the focus control  $\boxtimes$  on the adjustment control panel adjust the lines in the north-south direction for maximum sharpness. TV receivers with focusing panel: Subsequently, with the focus control  $\boxtimes$  on the focusing panel, adjust the lines in the east-west direction for maximum sharpness. Repeat if necessary.

**Attention:** For measurements on the focusing panel use only sufficiently insulated measuring cables and test probes with adequate electric strength (eg. 100:1).

### Videotext (VT) Matching Adjustment

At the time of delivery the control R378 is set to the lowest high-frequency emphasis. If, despite a perfect aerial signal, character faults occur, turn R378 slowly until the character errors disappear. Do not turn R378 any more as the error rate may increase again. During this adjustment page 199 must always be selected anew so that it is read in anew

making it possible to evaluate the error rate.

### Picture Geometry and Picture Position Adjustment via the Remote Control Handset

For accurate adjustment of the picture a test generator or standard test pattern should be used. For raster corrections it is also possible to use the integrated test pattern.

- 1: Call up the Geometry Menu via Info centre --> Special Functions --> Service --> code 8500.
- 2: If a standard test pattern is not available, move the bar with the cursor buttons to the menu item "Test Pattern On".

**Attention:** Start always with the "V-middle" adjustment otherwise the other vertical deflection parameters would defy correct geometry adjustment.

### "V-Middle" Adjustment with a Colour Test Pattern

- Select the "V-Middle" menu. The upper part of the picture is coloured, the lower part is black and white.
- With the  $\blacktriangleright$  or  $\blacktriangleleft$  buttons move the three broken lines on the left and on the right of the indication "V-Middle" upwards or downwards so that they coincide with the line separating the coloured part and the black/white part of the picture.
- Continue with the picture geometry adjustment via the menu and store.

V-Middle Adjustment with a Video Generator, eg. Grundig VG 1000

- Feed in the convergence test pattern with standard colour bars via RF.
- Call up the "V-Middle" menu.
- With the  $\blacktriangleright$  or  $\blacktriangleleft$  button change the setting so that the G-Y vector (orange area in the centre of the picture) is just covered.
- Continue with the picture geometry adjustment via the menu and store.

The "line shift" alignment influences the line phase setting. Before this adjustment set the horizontal amplitude to minimum and if necessary correct the raster position with the "Shift Plug". With button  $\blacktriangleright$  or  $\blacktriangleleft$  move the picture into the centre of the raster. Re-adjust the horizontal amplitude with the test pattern.

- 3: To store this adjustment, move the bar to "Terminate with store" and confirm with OK. The picture geometry is set to the last stored value whenever the receiver is switched on.

### Reset:

Under the menu item "Reset" an average data set from the ROM is stored. After inadvertent re-adjustment during servicing, these basic values can be re-loaded at any time. For this, move the yellow bar to "Reset", press the OK button. By pressing the "AUX" button the picture geometry is set according to this "Reset" values.

- 4: With the i button return to the normal menu.

## Interference Diagram

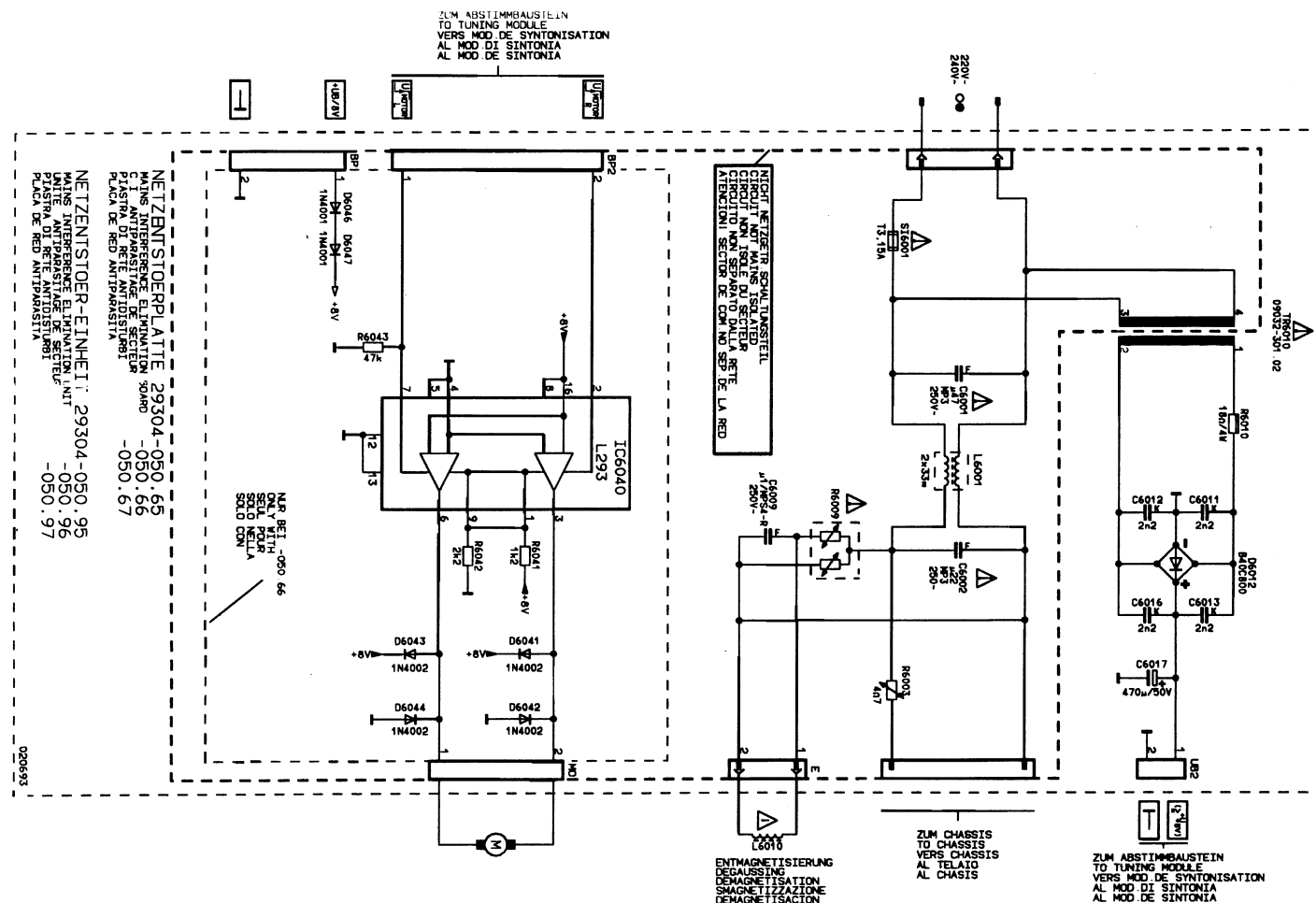

## Socket Diagram

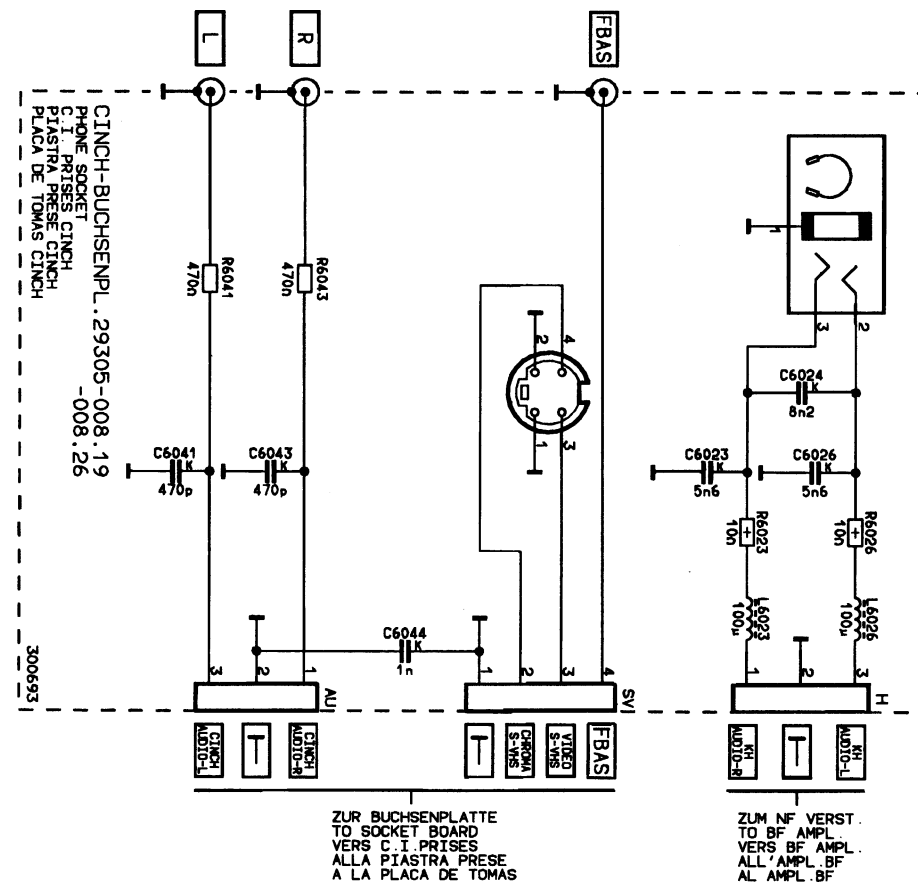

### AF Amp Diagram

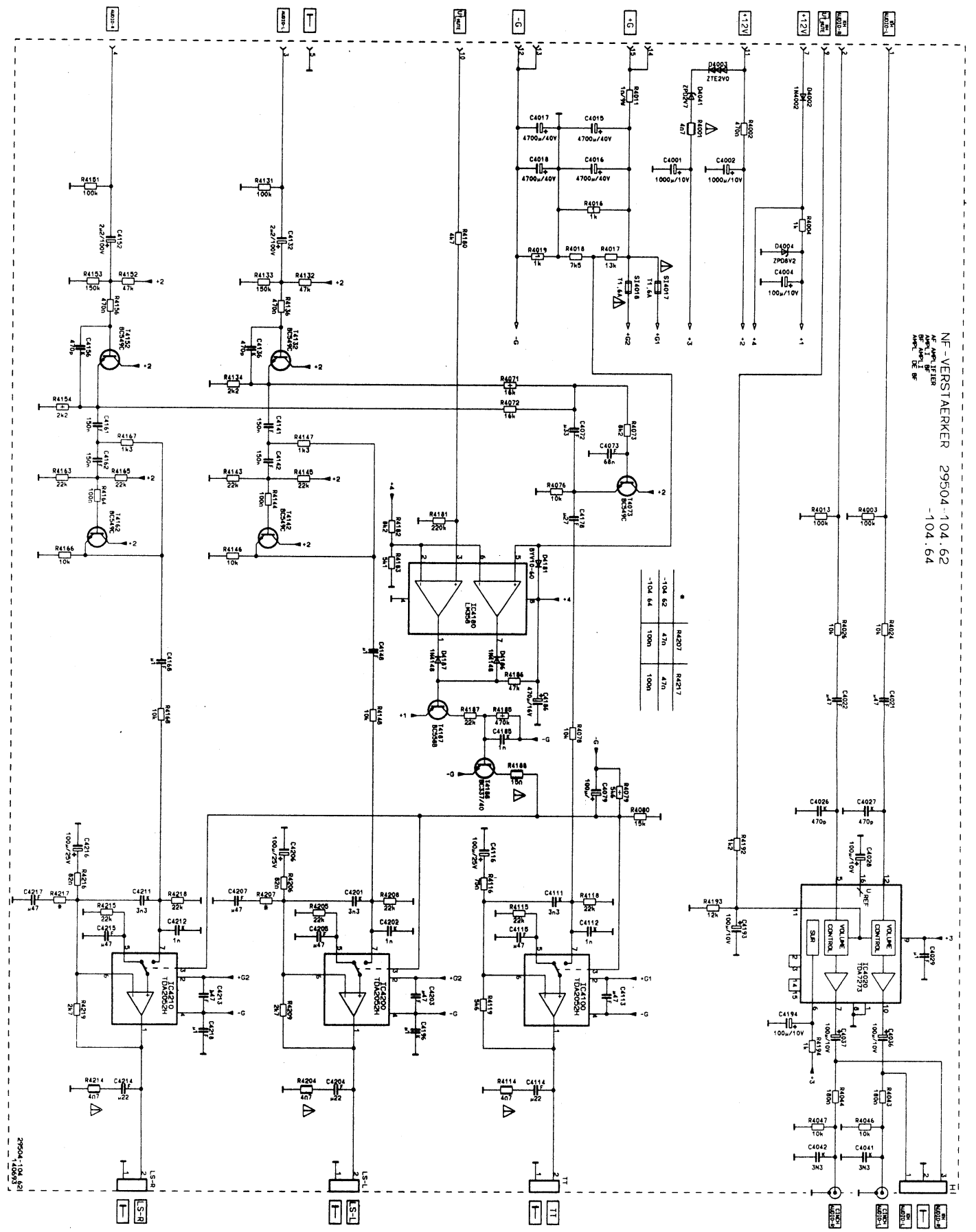

NF-VERSTÄRKER 29504-104.62  
 NF-AMP-VERSTÄRKER  
 29504-104.64

### IF Amp Diagram

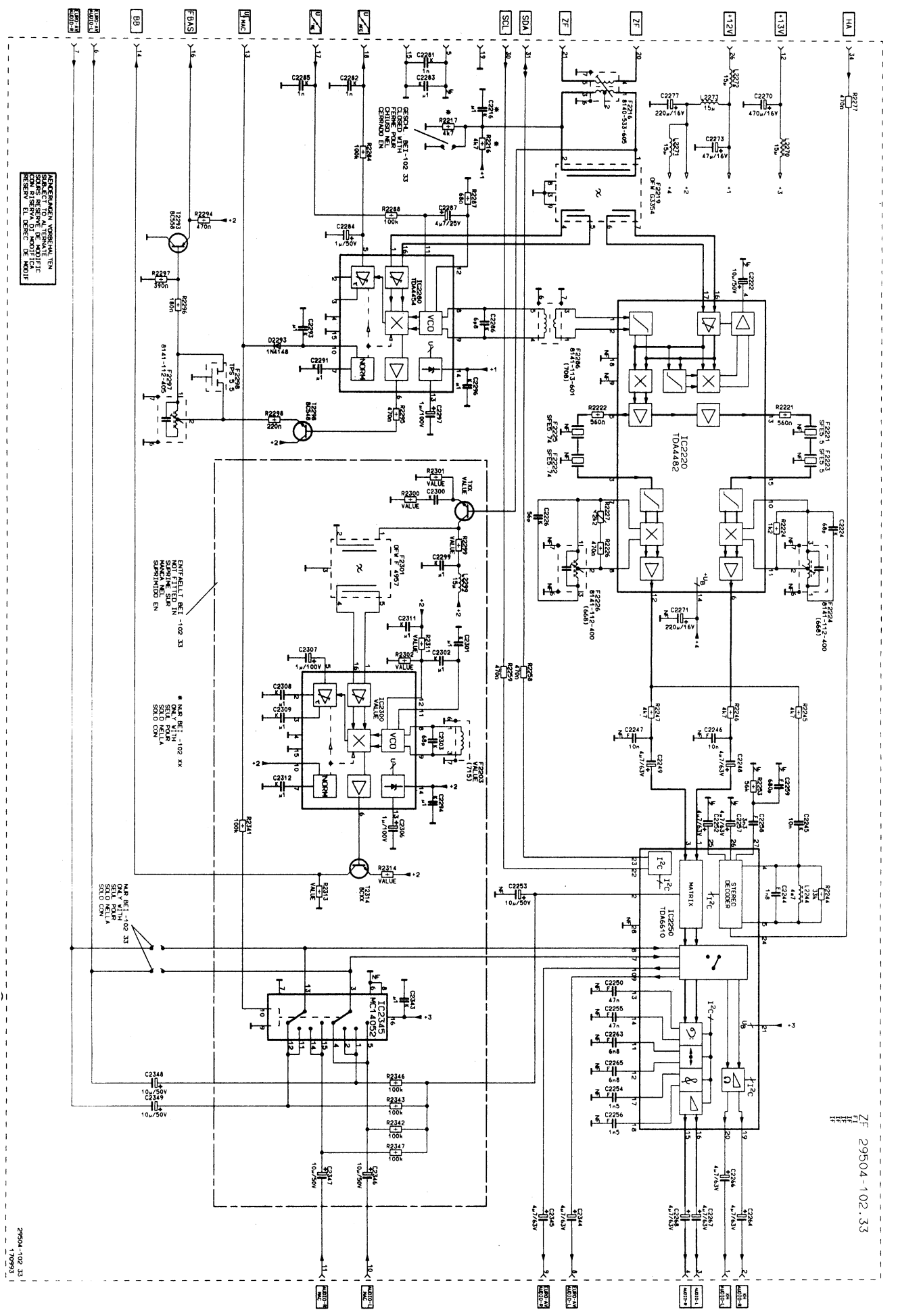

ZF 29504-102.33

